

## NERLITE® BAR LIGHT



### Compact Lighting Solution

Microscan's wide range of NERLITE products can illuminate any part or mark for successful machine vision and auto ID applications.

Bar lights are an economical source of uniform incident lighting in a low profile, compact shape. Useful for both dark field (creating shadows and specular reflection) and bright field lighting, adjustments to working distance and angle provide good image contrast on diffused surfaces. Models for continuous or strobe operation support static or high speed applications.

#### Bar Light: At a Glance

- Economical, general purpose design
- Provides even illumination in a concentrated area
- Address a broad range of applications via light positioning in bright field or dark field
- Variety of colors and sizes for both continuous and strobe operation
- Sturdy housings combined with LEDs rated at up to 50,000 hours
- Diffuser accessory included

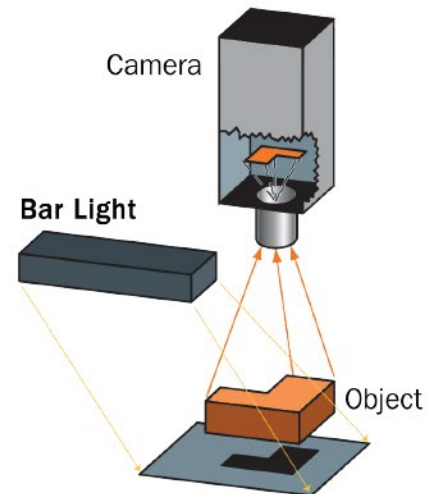

#### Illumination Example:

Object

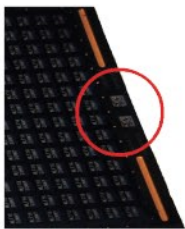

Resulting Image



**Circuit board:** Image captured shows high contrast Data Matrix symbols.

For more information on this product, visit [www.microscan.com](http://www.microscan.com).

#### Application Examples

- Locate or measure outside dimensions
- Illuminate flat, diffused surfaces
- Product defect inspection
- Label placement verification
- Non-diffuse incident (front) lighting
- Dark field or bright field lighting

# MICROSCAN®

# NERLITE® BAR LIGHT SPECIFICATIONS AND OPTIONS

## LA 50

DESCRIPTION	nm/K	CONT. CURRENT	STROBE CURRENT	mcd/cm <sup>2</sup>	
				DIFFUSE	NON-DIFFUSE
LA-50-1, Red Continuous	660 nm	23 mA		2980	5520
LA-50-1, Red Strobe	660 nm		400 mA	26000	48000
LA-50-1, White Continuous	6500 K	40 mA		3348	6200
LA-50-1, White Strobe	6500 K		784 mA	33480	62000
LA-50-1, Blue Continuous	470 nm	40 mA		2700	5000
LA-50-1, Blue Strobe	470 nm		784 mA	27000	50000

**Active Area:** 2" x 0.35" (51 mm x 8.9 mm) **Weight:** 3 oz. (78 g)  
**Dimensions:** H 0.75" (19.1 mm) x W 2.21" (56.1 mm) x D 0.6" (15.2 mm)

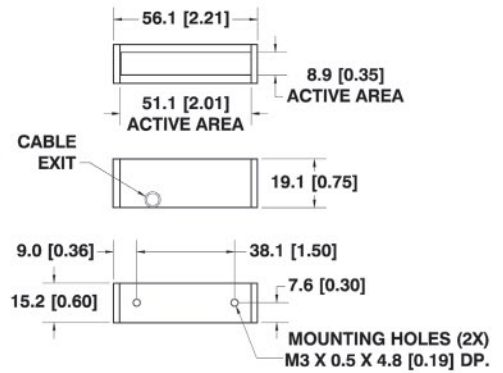

## LA 100

DESCRIPTION	nm/K	CONT. CURRENT	STROBE CURRENT	mcd/cm <sup>2</sup>	
				DIFFUSE	NON-DIFFUSE
LA-100-1, Red Continuous	660 nm	46 mA		2980	5520
LA-100-1, Red Strobe	660 nm		800 mA	26000	48000
LA-100-1, White Continuous	6500 K	80 mA		3348	6200
LA-100-1, White Strobe	6500 K		1.57 A	33480	62000
LA-100-1, Blue Continuous	470 nm	80 mA		2700	5000
LA-100-1, Blue Strobe	470 nm		1.57 A	27000	50000

**Active Area:** 4" x 0.35" (102 mm x 8.9 mm) **Weight:** 4 oz. (105 g)  
**Dimensions:** H 0.75" (19.1 mm) x W 4.21" (106.9 mm) x D 0.6" (15.2 mm)

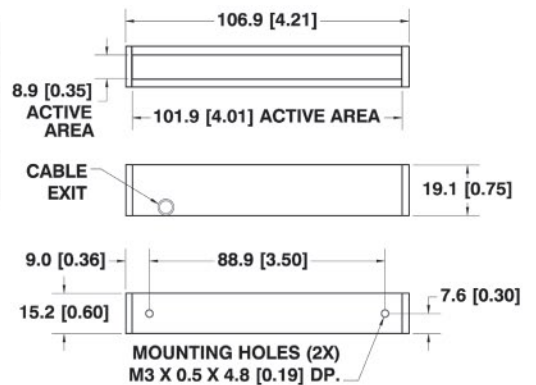

## LA 150

DESCRIPTION	nm/K	CONT. CURRENT	STROBE CURRENT	mcd/cm <sup>2</sup>	
				DIFFUSE	NON-DIFFUSE
LA-150-1, Red Continuous	660 nm	69 mA		2484	4600
LA-150-1, Red Strobe	660 nm		1.2 A	24840	46000
LA-150-1, White Continuous	6500 K	120 mA		3348	6200
LA-150-1, White Strobe	6500 K		2.35 A	33480	62000
LA-150-1, Blue Continuous	470 nm	120 mA		2700	5000
LA-150-1, Blue Strobe	470 nm		2.35 A	27000	50000

**Active Area:** 6" x 0.35" (153 mm x 8.9 mm) **Weight:** 5 oz. (136 g)  
**Dimensions:** H 0.75" (19.1 mm) x W 6.21" (157.7 mm) x D 0.6" (15.2 mm)

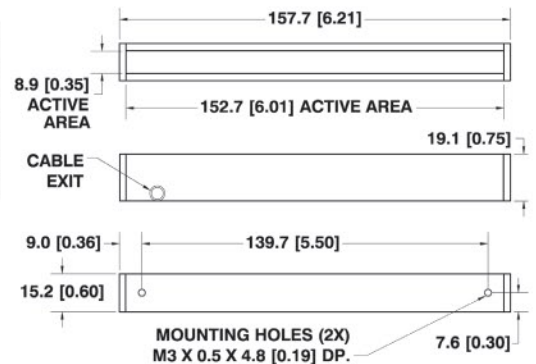

## ENVIRONMENTAL

**Operating Temperature:** 0° to 40° C (32° to 104° F)  
**Storage Temperature:** 0° to 50° C (32° to 122° F)  
**Humidity:** up to 95% (non-condensing)

## LIGHTING PARAMETERS

**Active Area Defined:** Area of light output from the illuminator.

## LIGHT SOURCE

**Type:** High output LEDs  
**Light Output:** Millicandelas per square centimeter (mcd/cm<sup>2</sup>)  
**Expected Life:** 50,000 hours (Red LEDs)  
**Expected Life:** 10,000 hours (Blue, White LEDs)  
**Eye Safety:** EN 60825-1: Class 1 (Red, White LEDs); Class 2 (Blue LEDs)

## CONNECTOR

**Type:** 15 ft. (4.5 m) integrated cable with flying leads

## ELECTRICAL

**Power (Continuous Models):** 24 VDC +/- 1%  
**Power (Strobe Models):** 1 ms max. pulse width, 6% max duty cycle, use of NERLITE NL-200 Series Lighting Controller is required.



**DARTRONICS, INC.**

PACKAGING AUTOMATION SPECIALISTS



150 WILLIAM ST. PERTH AMBOY, NJ 08861 / TOLL FREE: 800-298-8936 / PHONE: 732-324-0800 / FAX: 732-324-4488

WWW.DARTRONICS.COM

YOUTUBE / DARTRONICS

THE SINGLE SOURCE FOR YOUR

END - OF - LINE

PACKAGING, MARKING AND CODING NEEDS